

# AYRLITE®

Anodised Aluminium Extrusion Suite  
for 6mm Honeycomb Sandwich Panels



**AYRES**  
Lightweight Panel Systems  
[www.ayrescom.com](http://www.ayrescom.com)

DATA SHEET Issue 2

## Description

The **AYRLITE** extrusion suite is a suite of four anodised aluminium profiles, plus one black PVC trim, to suite 6mm thick **AYRLITE** honeycomb panels

Each extrusion is available in 4800mm lengths.

The Joiners (ICT-122 and ICT-094) and Internal Corner (ICT-115) are rivetted to vessel structure. The ICT-122 Joiner is rivetted or screwed down the centre of the extrusion, which can be covered later by clipping the PCT-04 black PVC trim into place. Polyurethane adhesive (eg Sikaflex 291) is used for assembly. The End Cap (ICT-112) simply pushes onto the edge of the panel, again with polyurethane adhesive to keep it in place.

A DVD is available, showing assembly techniques contact Ayres Composite Panels for a copy.

## Safety

As with cutting operations on most materials, avoid inhalation and eye contact with machining dust. Wear protective equipment such as hearing protection and safety glasses during any cutting operations. Use machine guards. Wear gloves to avoid cuts. Wash hands before eating, drinking or smoking and after finishing work.

## Features

- Aluminium alloy 6063 T5
- Suits 6mm panels
- Available in 4800mm lengths
- Clear anodised finish, 10µm thickness

Description	Weight
ICT-094 Joiner	0.13 kg/m
ICT-112 End Cap	0.11 kg/m
ICT-115 Internal Corner	0.18 kg/m
ICT-122 Joiner	0.27 kg/m
PCT-04 PVC Trim	0.03 kg/m

### Ayres Composite Panels Pty Ltd

ABN 84 071 540 568

#### Australia Head Office and Manufacturing

25-27 Clune Street  
Bayswater WA 6053, Australia  
Tel: +61 (0) 8 9279 3426 Fax: +61 (0) 8 9279 6192  
[australia@ayrescom.com](mailto:australia@ayrescom.com)

#### USA Office and Manufacturing

5460 Business Parkway  
Theodore Alabama 36582, USA  
Tel: +1 251-653-0700 Fax: +1 251-653-7701  
[usa@ayrescom.com](mailto:usa@ayrescom.com)

#### Europe Office (Belgium)

Tel: +32 (0) 87 891245 Fax: +32 (0) 87 891246  
[europe@ayrescom.com](mailto:europe@ayrescom.com)

[www.ayrescom.com](http://www.ayrescom.com)

*Lighten Up!*

© Registered Trade Mark of Ayres Composite Panels

**IMPORTANT** All information is given in good faith but without acceptance of liability. Ayres Composite Panels reserves the right to alter specification without prior notice. It remains the responsibility of the customer to ensure the suitability of any product for the purposes intended. All sales are made subject to Ayres Composite Panels [standard terms and conditions of sale](#). Please direct all [enquiries here](#).

# AYRLITE®

Anodised Aluminium Extrusion Suite  
for 6mm Honeycomb Sandwich Panels



# AYRES

Lightweight Panel Systems  
[www.ayrescom.com](http://www.ayrescom.com)

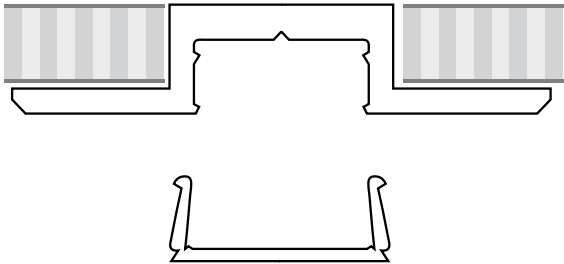

**Weight** 0.27 kg/m

**ICT-122 Joiner**  
**PCT-04 PVC Trim for ICT-122 Joiner**

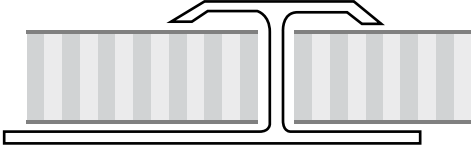

**Weight** 0.13 kg/m

**ICT-094 Joiner**

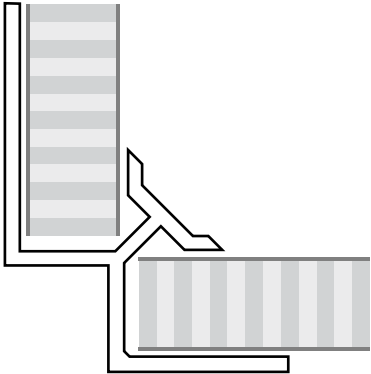

**Weight** 0.18 kg/m

**ICT-115 Internal Corner**

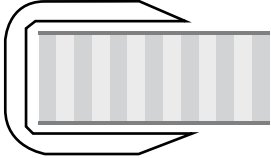

**Weight** 0.11 kg/m

**ICT-112 End Cap**