



The **AYRLITE aluminum extrusion suite** consists of 20 profiles to suit 0.4, 0.8 and 1.2inch panels.

AYRLITE honeycomb panels are assembled with extrusions using polyurethane adhesive (eg Sikaflex 291). For the 0.4inch Corner Post (ACP2853), End Cap (ACP2855) and Joiner (ACP2856) the honeycomb panel edges are slotted to accept the extrusion tongue.

Slot cutters and polyurethane adhesive are available from Ayres Composite Panels if required.

A CD is available, showing assembly techniques (contact Ayres Composite Panels for a copy).

Features

- Aluminum alloy 6063 T5.
- Suits 0.4, 0.8 and 1.2inch panels.
- Standard extrusion length is 96inches, although lengths up to 192inches are available.
- Clear anodized finish, 10µm thickness.

Safety

As with cutting operations on most materials, avoid inhalation and eye contact with machining dust. Wear protective equipment such as hearing protection and safety glasses during any cutting operations. Use machine guards. Wear gloves to avoid cuts. Wash hands before eating, drinking or smoking and after finishing work.

Description	Weight
-------------	--------

0.4inch Extrusions

ACP8529 Corner Post	0.07 lb/ft
ACP8587 Cabinet Door Jamb	0.02 lb/ft
ACP131 End Cap	0.02 lb/ft
ACP130 Joiner	0.04 lb/ft
ACP80991 End Stop	0.02 lb/ft

0.8inch Extrusions

ACP2853 Corner Post	0.10 lb/ft
ACP2854 Cabinet Door Jamb	0.03 lb/ft
ACP2855 End Cap (With Tongue)	0.04 lb/ft
ACP2856 Joiner	0.05 lb/ft
ACP2857 Channel	0.04 lb/ft
ACP8667 Shelf Edge	0.06 lb/ft
ACP80197 Door Stile	0.24 lb/ft
ACP80198 Door Jamb	0.11 lb/ft
ACP25824 Door Jamb Joiner	0.06 lb/ft/set of 4
ACP80360 End Cap (No Tongue)	0.02 lb/ft
ACP81011 Interlocking End Cap	0.09 lb/ft

1.2inch Extrusions

ACP8629A Table Edge	0.04 lb/ft
ACP8629B Table Edge (Mill Finish)	0.04 lb/ft

Universal Extrusions

ACP80355 Bead Strip	0.01 lb/ft
ACP80356 Internal Joiner (Mill Finish)	0.02 lb/ft
ACP80361 Corner Trim	0.04 lb/ft





0.8inch Extrusions

Clear Anodized Aluminum Extrusion Suite

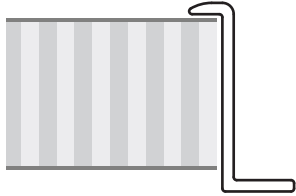

Weight 0.11 lb/ft

ACP2854 - 0.8" Cabinet Door Jamb

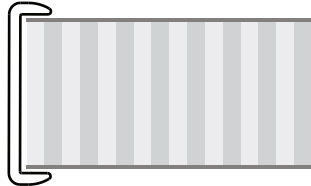

Weight 0.08 lb/ft

ACP80360 - 0.8" End Cap (No Tongue)

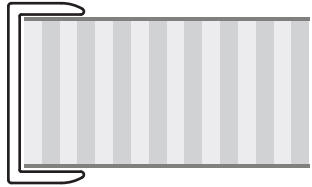

Weight 0.11 lb/ft

ACP2857 - 0.8" Channel Small

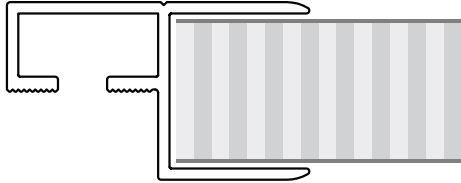

Weight 0.28 lb/ft

**ACP81011 - 0.8" Interlocking End Cap
(145" maximum length)**



0.8inch Extrusions

Clear Anodized Aluminum Extrusion Suite

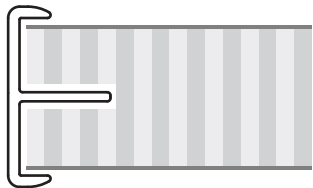

Weight 0.11 lb/ft

ACP2855 - 0.8" End Cap (With Tongue)

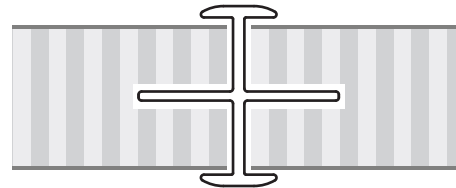

Weight 0.16 lb/ft

ACP2856 - 0.8" Joiner

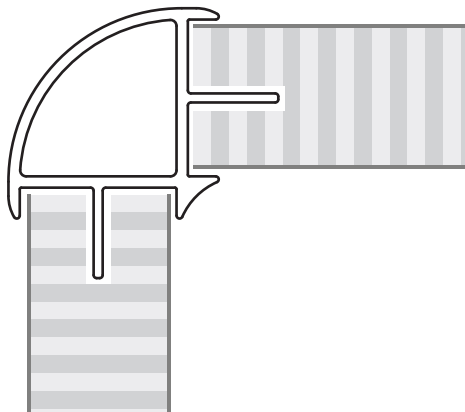

Weight 0.32 lb/ft

ACP2853 - 0.8" Corner Post

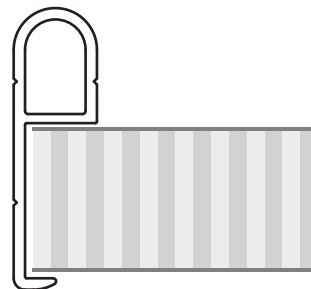

Weight 0.18 lb/ft

ACP8667 - 0.8" Shelf Edge



0.4inch Extrusions

Clear Anodized Aluminum Extrusion Suite

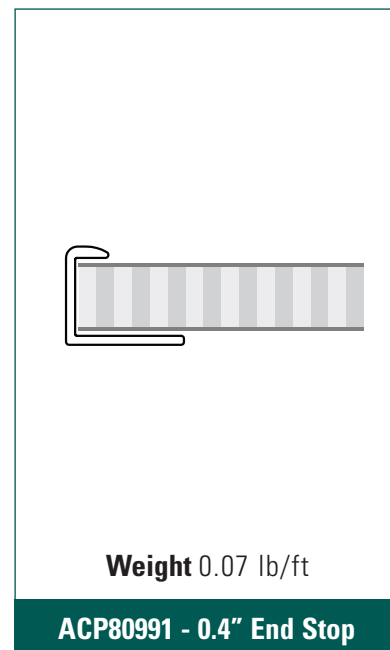
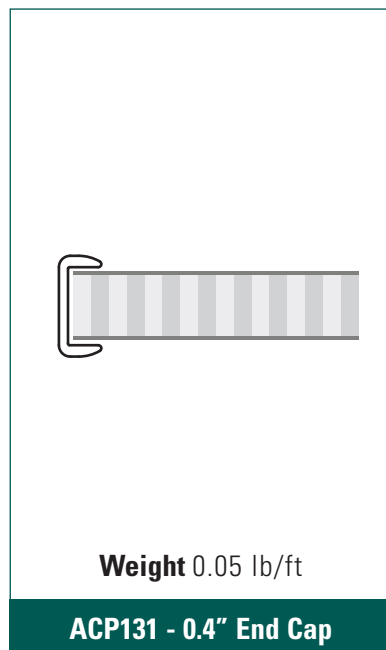
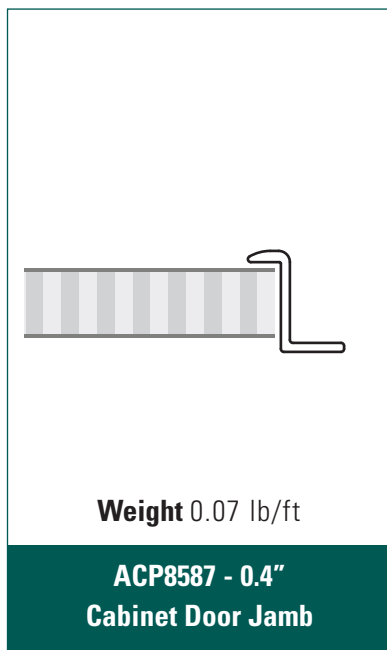
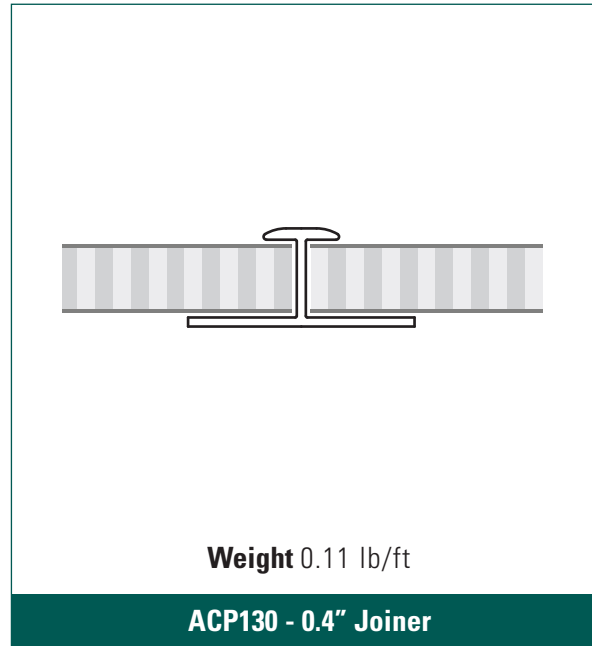
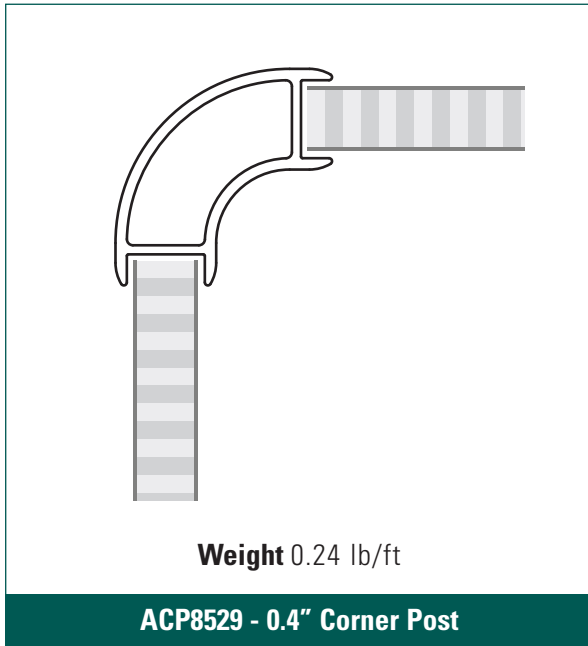



0.8inch Door System

Clear Anodized Aluminum Extrusion Suite

(See separate Door System Data Sheet for further details)

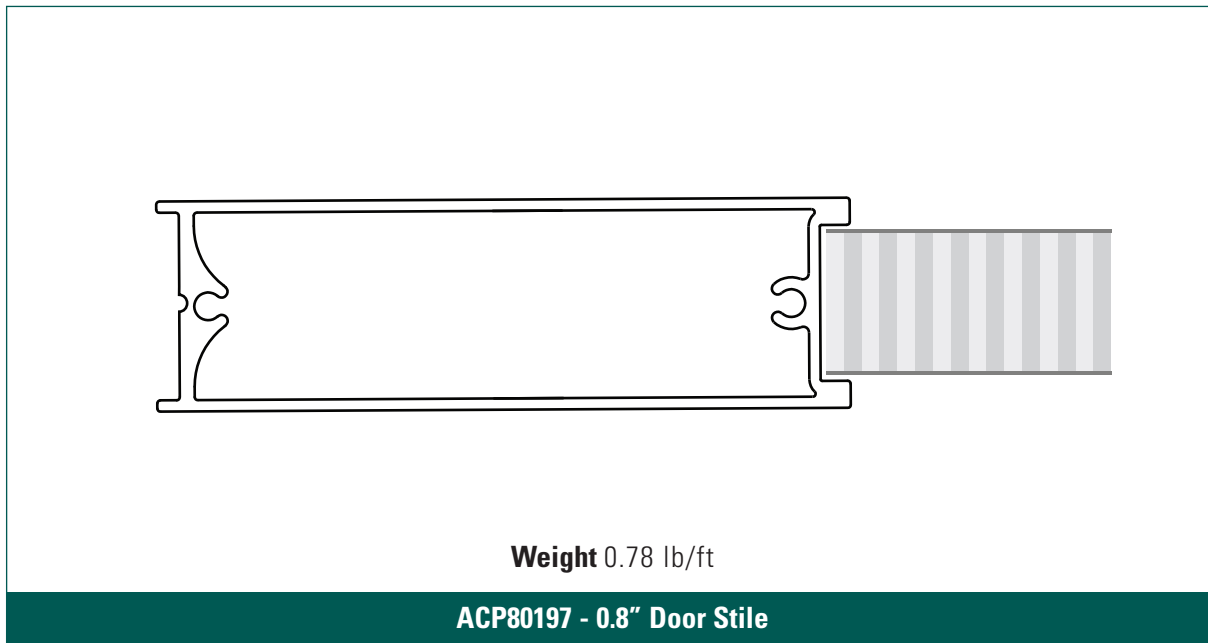
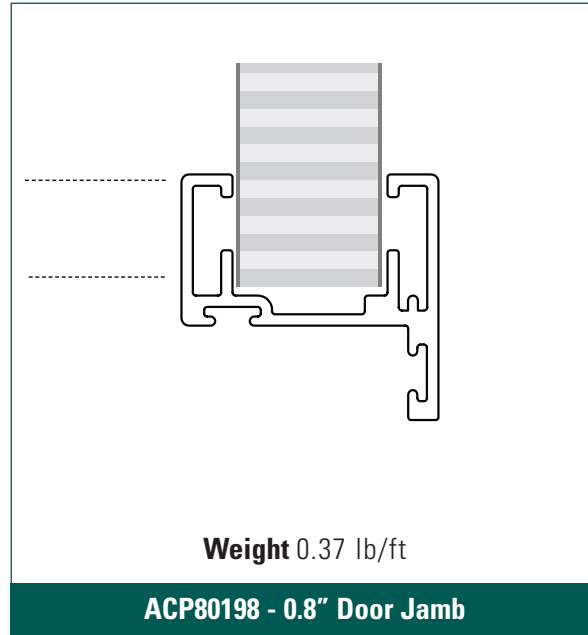
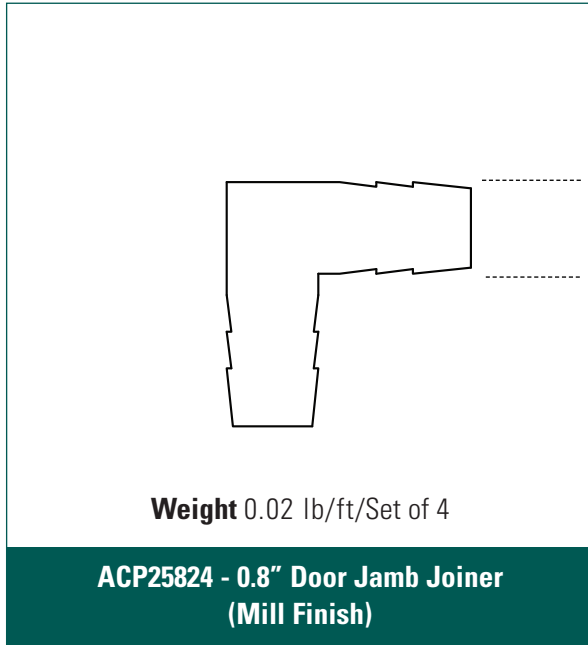

Universal Extrusions

Clear Anodized Aluminum Extrusion Suite

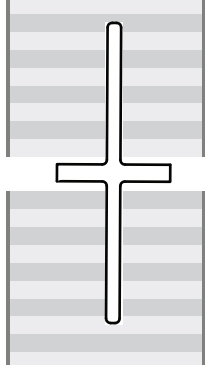
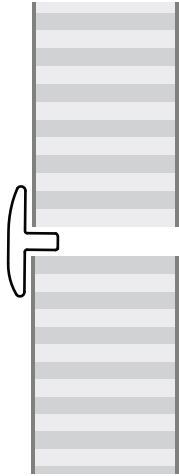
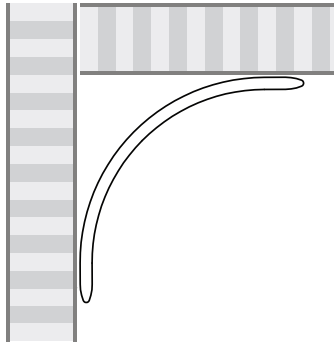
 <p>Weight 0.08 lb/ft</p> <p>ACP80356 - Internal Joiner (Mill Finish) (Suitable for Panels 0.4" and over)</p>	 <p>Weight 0.03 lb/ft</p> <p>ACP80355 - Bead Strip</p>	 <p>Weight 0.12 lb/ft</p> <p>ACP80361 - Corner Trim</p>
------------------------------------------------------------------------------------------------------------------------------------------------------------------------------------------------------------------	-------------------------------------------------------------------------------------------------------------------------------------------------------	----------------------------------------------------------------------------------------------------------------------------------------------------------

1.2inch Extrusions

 <p>Weight 0.14 lb/ft</p> <p>ACP8629A - 1.2" Table Edge (Clear Anodized) ACP8629B - 1.2" Table Edge (Mill Finish) (Mill finish extrusion for forming to shape before anodising or powder coating.)</p>	<p>Ayres Composite Panels USA LLC</p> <p>USA Office and Manufacturing 5460 Business Parkway Theodore Alabama 36582, USA Tel: +1 251-653-0700 Fax: +1 251-653-7701 usa@ayrescom.com</p> <p>Australia Office and Manufacturing 25-27 Clune Street Bayswater WA 6053, Australia Tel: +61 (0) 8 9279 3426 Fax: +61 (0) 8 9279 6192 australia@ayrescom.com</p> <p>Europe Office (Belgium) Tel: +32 (0) 87 891245 Fax: +32 (0) 87 891246 europe@ayrescom.com</p> <p>www.ayrescom.com</p> <p><i>Lighten Up!</i></p>
------------------------------------------------------------------------------------------------------------------------------------------------------------------------------------------------------------------------------------------------------------------------------------------------------------------------	-----------------------------------------------------------------------------------------------------------------------------------------------------------------------------------------------------------------------------------------------------------------------------------------------------------------------------------------------------------------------------------------------------------------------------------------------------------------------------------------------------------------------------------------------------------------------------------------

© Registered Trade Mark of Ayres Composite Panels

IMPORTANT All information is given in good faith but without acceptance of liability. Ayres Composite Panels reserves the right to alter specification without prior notice. It remains the responsibility of the customer to ensure the suitability of any product for the purposes intended. All sales are made subject to our standard terms and conditions of sale. (Copy available on request).