



The **AYRLITE aluminium extrusion suite** consists of 20 profiles to suit 10, 20 and 30mm panels.

AYRLITE honeycomb panels are assembled with extrusions using polyurethane adhesive (eg Sikaflex 291). For the 20mm Corner Post (ACP2853), End Cap (ACP2855) and Joiner (ACP2856) the honeycomb panel edges are slotted to accept the extrusion tongue.

Slot cutters and polyurethane adhesive are available from Ayres Composite Panels if required.

A CD is available, showing assembly techniques (contact Ayres Composite Panels for a copy).

Features

- Aluminium alloy 6063 T5.
- Suits 10, 20 and 30mm panels.
- Standard extrusion length is 2440mm, although lengths up to 4900mm are available.
- Clear anodised finish, 10µm thickness.

Safety

As with cutting operations on most materials, avoid inhalation and eye contact with machining dust. Wear protective equipment such as hearing protection and safety glasses during any cutting operations. Use machine guards. Wear gloves to avoid cuts. Wash hands before eating, drinking or smoking and after finishing work.

Description

Weight

10mm Extrusions

ACP8529 Corner Post	0.36 kg/m
ACP8587 Cabinet Door Jamb	0.10 kg/m
ACP131 End Cap	0.08 kg/m
ACP130 Joiner	0.17 kg/m
ACP80991 End Stop	0.10 kg/m

20mm Extrusions

ACP2853 Corner Post	0.47 kg/m
ACP2854 Cabinet Door Jamb	0.16 kg/m
ACP2855 End Cap (With Tongue)	0.17 kg/m
ACP2856 Joiner	0.24 kg/m
ACP2857 Channel	0.17 kg/m
ACP8667 Shelf Edge	0.27 kg/m
ACP80197 Door Stile	1.16 kg/m
ACP80198 Door Jamb	0.55 kg/m
ACP25824 Door Jamb Joiner	30g/set of 4
ACP80360 End Cap (No Tongue)	0.12 kg/m
ACP81011 Interlocking End Cap	0.42kg/m

30mm Extrusions

ACP8629A Table Edge	0.21 kg/m
ACP8629B Table Edge (Mill Finish)	0.21 kg/m

Universal Extrusions

ACP80355 Bead Strip	0.05 kg/m
ACP80356 Internal Joiner (Mill Finish)	0.12 kg/m
ACP80361 Corner Trim	0.18 kg/m



20mm Door System

Clear Anodised Aluminium Extrusion Suite

(See separate Door System Data Sheet for further details)

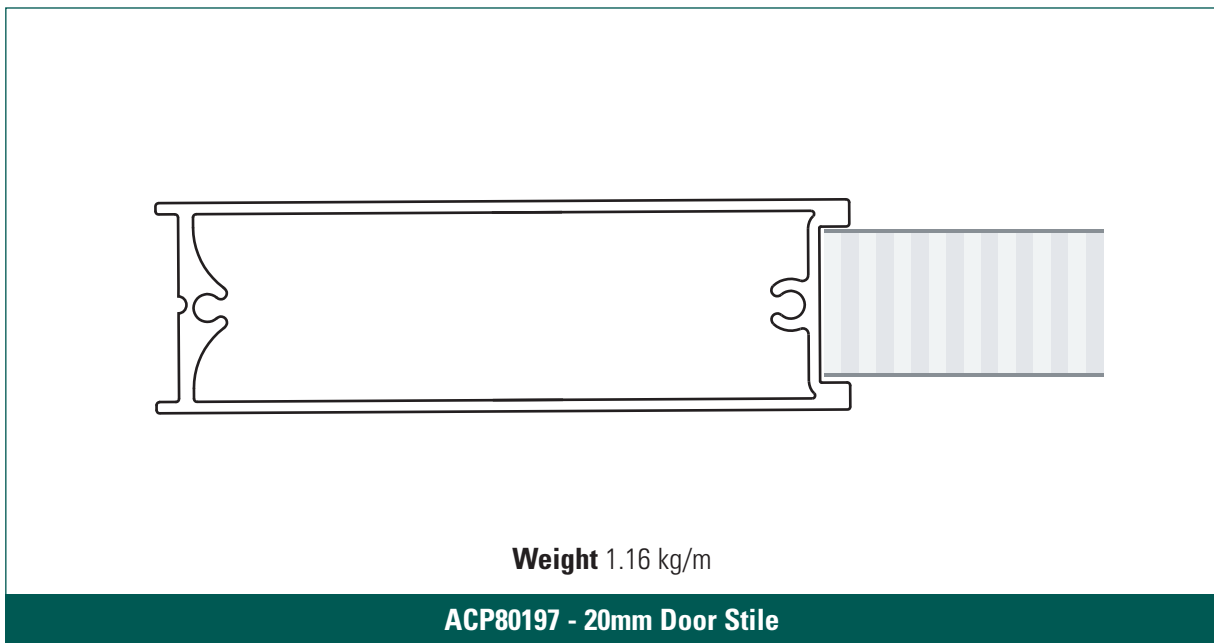
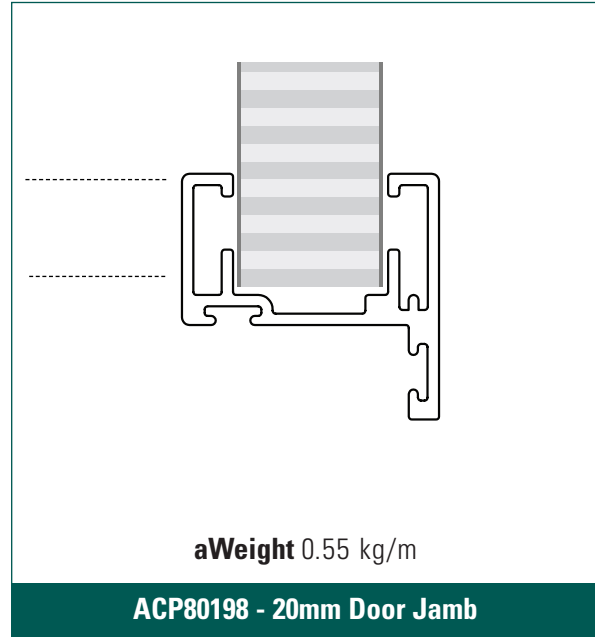
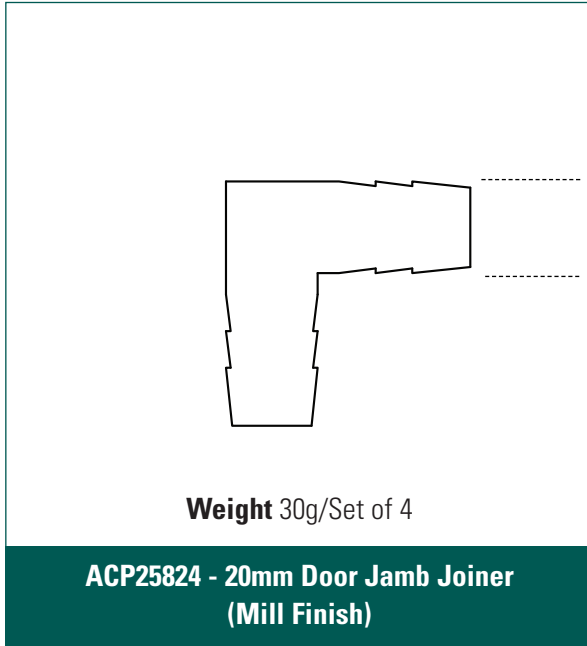

10mm Extrusions

Clear Anodised Aluminium Extrusion Suite

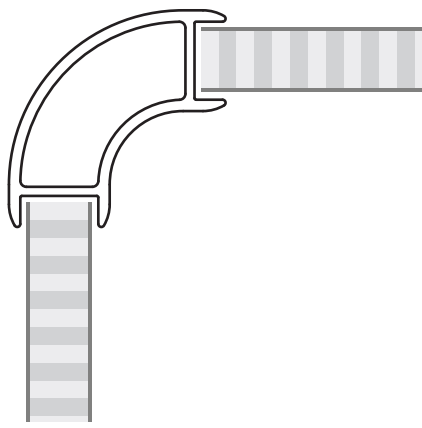

Weight 0.36 kg/m

ACP8529 - 10mm Corner Post

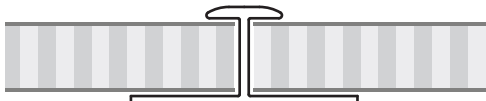

Weight 0.17 kg/m

ACP130 - 10mm Joiner

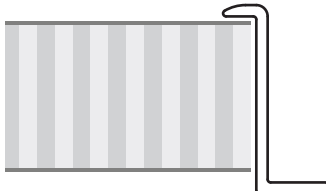

Weight 0.10 kg/m

ACP8587 - 10mm Cabinet Door Jamb

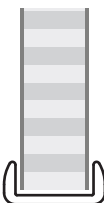

Weight 0.08 kg/m

ACP131 - 10mm End Cap

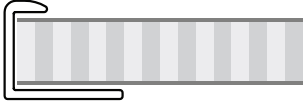

Weight 0.10 kg/m

ACP80991 - 10mm End Stop



20mm Extrusions

Clear Anodised Aluminium Extrusion Suite

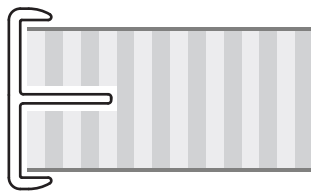

Weight 0.17 kg/m

ACP2855 - 20mm End Cap (With Tongue)

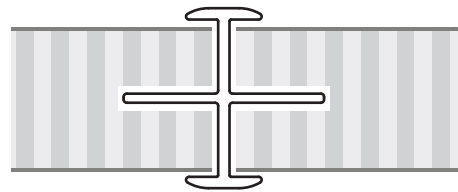

Weight 0.24 kg/m

ACP2856 - 20mm Joiner

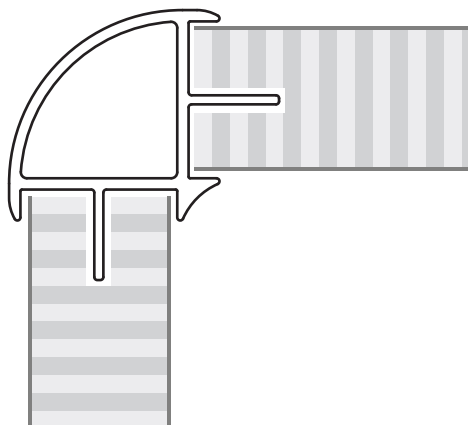

Weight 0.47 kg/m

ACP2853 - 20mm Corner Post

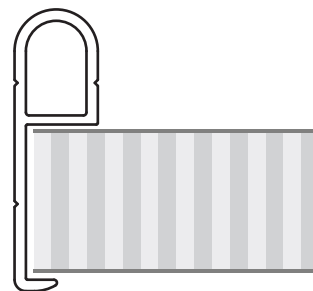

Weight 0.27 kg/m

ACP8667 - 20mm Shelf Edge



20mm Extrusions

Clear Anodised Aluminium Extrusion Suite

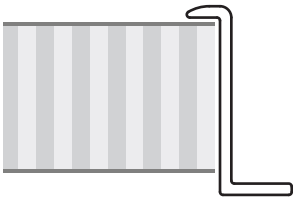

Weight 0.16 kg/m

ACP2854 - 20mm Cabinet Door Jamb

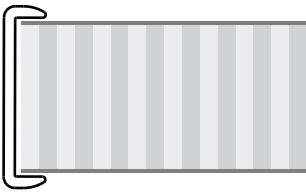

Weight 0.12 kg/m

ACP80360 - 20mm End Cap (No Tongue)

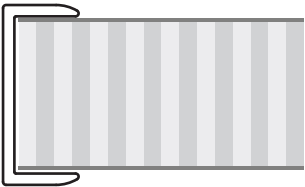

Weight 0.17 kg/m

ACP2857 - 20mm Channel Small

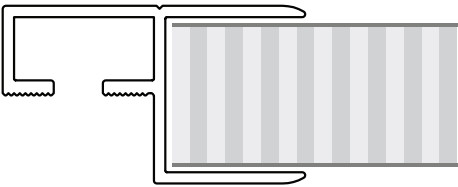

Weight 0.42 kg/m

ACP81011 - 20mm Interlocking End Cap
(3700mm maximum length)



Universal Extrusions

Clear Anodised Aluminium Extrusion Suite

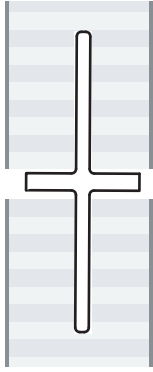

Weight 0.08 kg/m

ACP80356 - Internal Joiner (Mill Finish)
(Suitable for Panels 10mm and over)

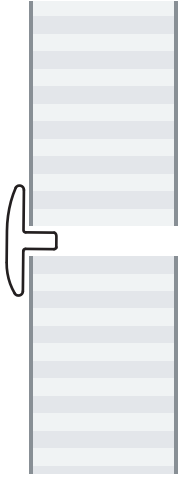

Weight 0.05 kg/m

ACP80355 - Bead Strip

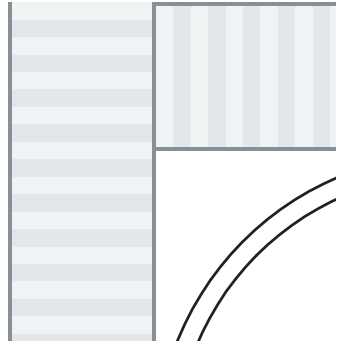

Weight 0.18 kg/m

ACP80361 - Corner Trim

30mm Extrusions

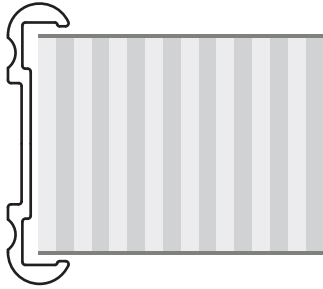

Weight 0.21 kg/m

ACP8629A - 30mm Table Edge (Clear Anodised)
ACP8629B - 30mm Table Edge (Mill Finish)
(Mill finish extrusion for forming to shape before anodising or powder coating.)

Ayres Composite Panels Pty Ltd

ABN 84 071 540 568

Australia Head Office and Manufacturing

25-27 Clune Street
Bayswater WA 6053, Australia
Tel: +61 (0) 8 9279 3426 Fax: +61 (0) 8 9279 6192
australia@ayrescom.com

USA Office and Manufacturing

5460 Business Parkway
Theodore Alabama 36582, USA
Tel: +1 251-653-0700 Fax: +1 251-653-7701
usa@ayrescom.com

Europe Office (Belgium)

Tel: +32 (0) 87 891245 Fax: +32 (0) 87 891246
europe@ayrescom.com

www.ayrescom.com

Lighten Up!

© Registered Trade Mark of Ayres Composite Panels

IMPORTANT All information is given in good faith but without acceptance of liability. Ayres Composite Panels reserves the right to alter specification without prior notice. It remains the responsibility of the customer to ensure the suitability of any product for the purposes intended. All sales are made subject to our standard terms and conditions of sale. (Copy available on request).